



multiload

# Trailing-edge Dimmer ADT400

0-10V controlled trailing-edge dimmer  
housed in a DIN-rail enclosure  
10W to 400W

## Contents

---

<b>Technical specification and installation</b>	<b>2</b>
<b>Related product options</b>	<b>3</b>
<b>Wiring diagrams</b>	
Rotary Push-control Wall Dimmer RPC	3
Rotary Push-switch Wall Dimmer RPS allowing multiple switch positions	4
Rotary Push-control Wall dimmer RPC using global output	4
MoodMaker channel	5
Take Control Unit with multiple position rotary dimming	5

## Product order code

---

**ADT400**  
Trailing-edge Dimmer



## Technical specification and installation

### Function

The Trailing-edge Dimmer ADT400 is connected to the mains supply and provides regulated power for all dimmable loads dimmable by trailing-edge technology.

It is controlled by a standard 0-10V signal, which may come from a simple wall plate rotary control (such as Rotary Push-control Wall Dimmer RPC) or from a lighting control system (such as MoodMaker).

ADT400 includes a relay which switches 'off' and isolates the phase-controlled variable live dimming output when the input signal falls below 1V. If different switching voltage is required, contact Multiload.

### Technical specification

#### Mains input voltage

230 Volts AC +/-10% 50Hz (Protected by MCB)

Note: ADT400 accepts only a normal full sine wave

#### Load rating

Minimum load 10W. Maximum load 400W

See Compatibility below

#### Ambient temperature

-10 to 40°C

#### SoftStart

Turns on lamps smoothly

#### Terminal connections

Each terminal accepts cable up to 4mm<sup>2</sup>

#### Mains supply terminal

L (live): N (neutral)

#### Load output terminals

N (neutral); VL (unswitched variable live), VL1 (variable live, switched off below 1V)

#### Signal input

C1 (0V), C2 (0-10V signal);

Global ON, OFF

#### DC output

0V, 15V. 50mA maximum output current

#### Overload protection

If an overload occurs on one of the variable live outputs (VL, VL1) the output automatically turns OFF. Switch off mains supply, remove overload, and switch on mains supply to restore power

#### Safety

The product complies with European Safety Regulations (IEC669-2-1) when used in lighting circuits containing MCBs. 6A recommended

### Compatibility

The unit is compatible with:

- Mains dimmable LEDs and mains dimmable drivers for constant voltage and constant current LEDs  
We recommend ADT400 is de-rated to a maximum of 200W for LED loads
- Mains voltage incandescent lamps
- Low voltage electronic transformers dimmable by trailing-edge phase control
- Mains halogen lamps
- Other sources – contact Multiload



### Installation

ADT400 is a DIN-rail mounted product which should be installed in a suitable location. It is not supplied with a DIN-rail cabinet (contact Multiload if you need us to supply the cabinet).

It can also be installed as a standalone version, for direct screw mounting in a suitable enclosure, by extending the lugs attached to the base of the enclosure.

Installation should be carried out by suitably qualified personnel in accordance with good electrical practice and the appropriate national wiring regulations.

The product complies with European Safety Regulations (IEC669-2-1) when used in lighting circuits containing MCBs. 6A recommended.

Switch off mains electrical supply before commencing installation.

Removing low level flicker on some mains dimmable LEDs.

Due to the characteristics of some mains dimmable LED lamps (or drivers), dimmable by trailing edge technology, the lamps may flicker at low brightness levels. This flicker can be eliminated when using the Multiload Push-Control Dimmer (RPC – see Related Product Options) by adjusting the minimum preset to a higher level; or when using a lighting control system, such as Multiload's MoodMaker Scene-setting System (see related product options on page 3) by setting appropriate brightness levels.

### Physical data

**Weight:** 270g

**Finish:** Plastic

**Dimensions:** W:88mm D:90mm H:58mm



# Trailing-edge Dimmer ADT400 related product options

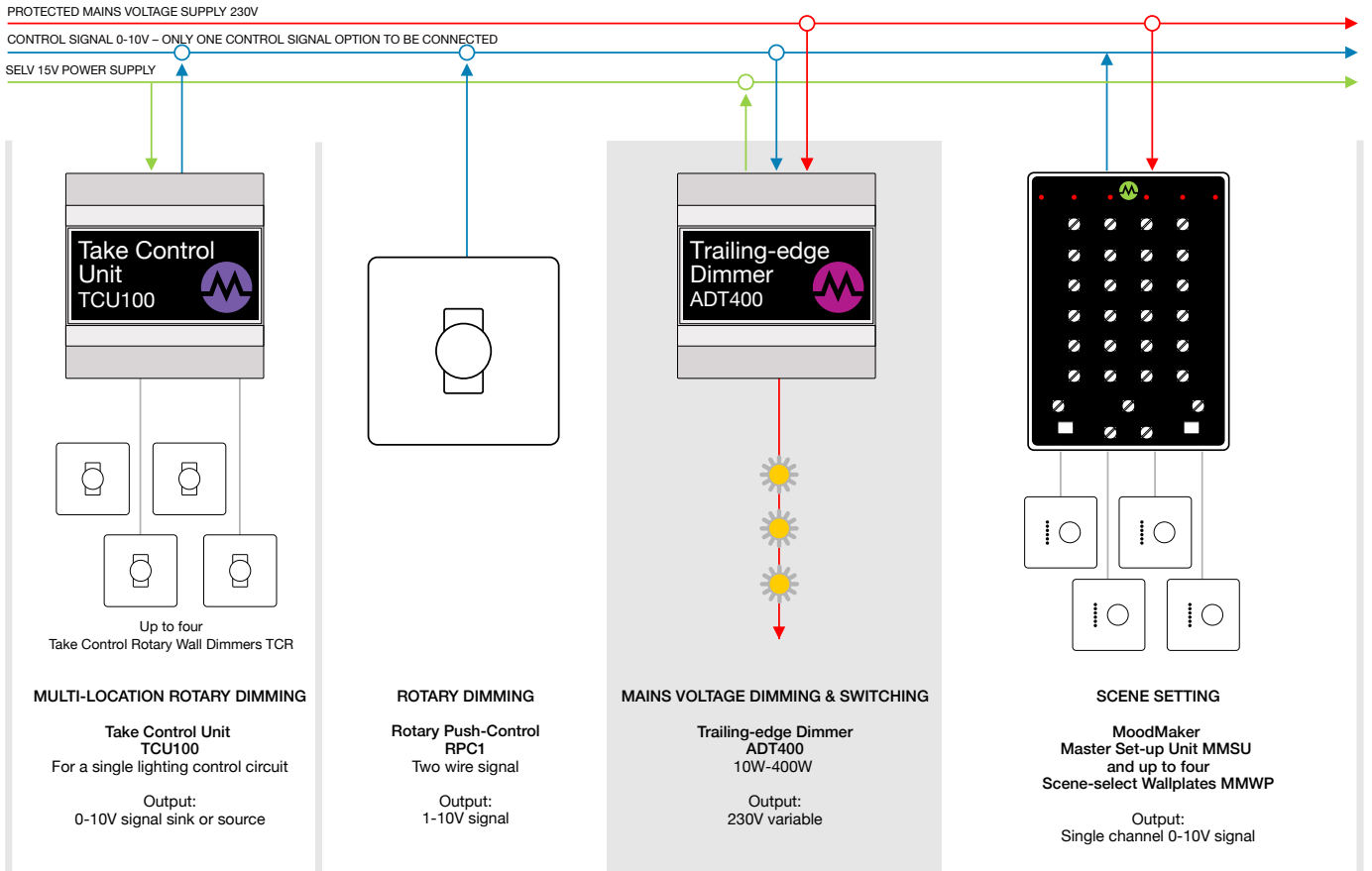

## Trailing-edge Dimmer ADT400 wired to Rotary Push-control Wall Dimmer RPC

### Trailing-edge Dimmer ADT400 installed with Rotary Push-control Wall Dimmer RPC1

Rotary Push-control Wall Dimmer RPC2 is used when controlling a circuit with more than one Trailing-edge Dimmer ADT400

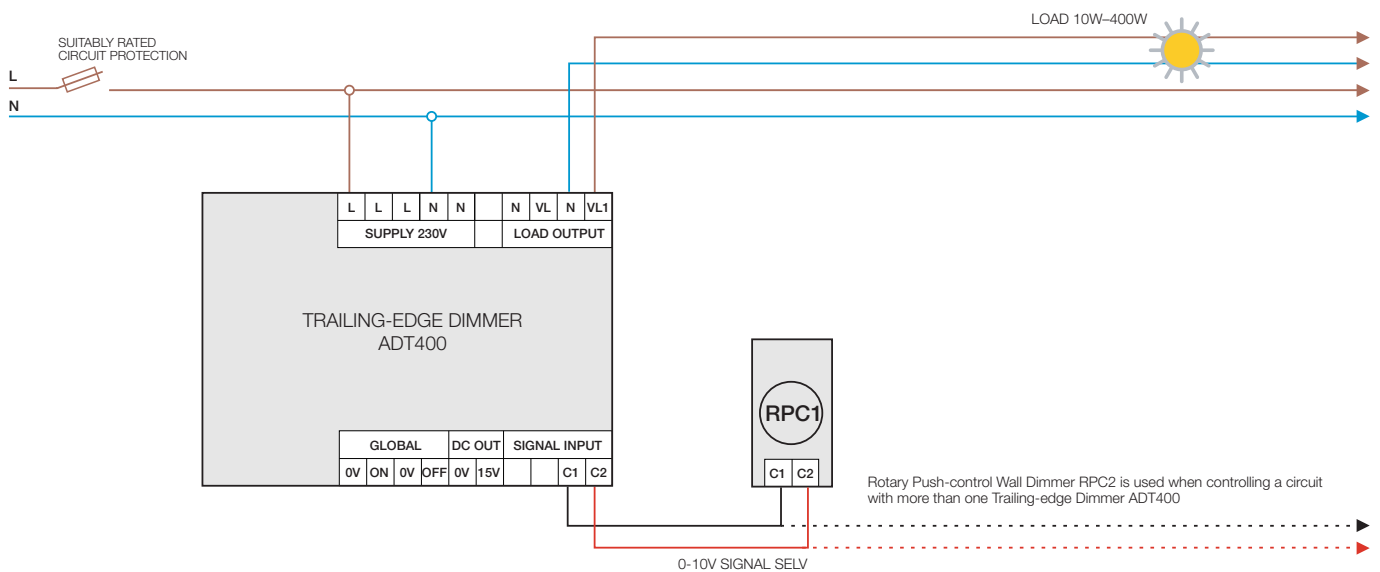

DRAWING NOT TO SCALE WD-ADT400-RPC. ISS-1-0116



# Trailing-edge Dimmer ADT400 wired to Rotary Push-switch Wall Dimmer RPS with multiple switch positions

Trailing-edge Dimmer ADT400 with multiple switch positions installed with Rotary Push-switch Wall Dimmer RPS1

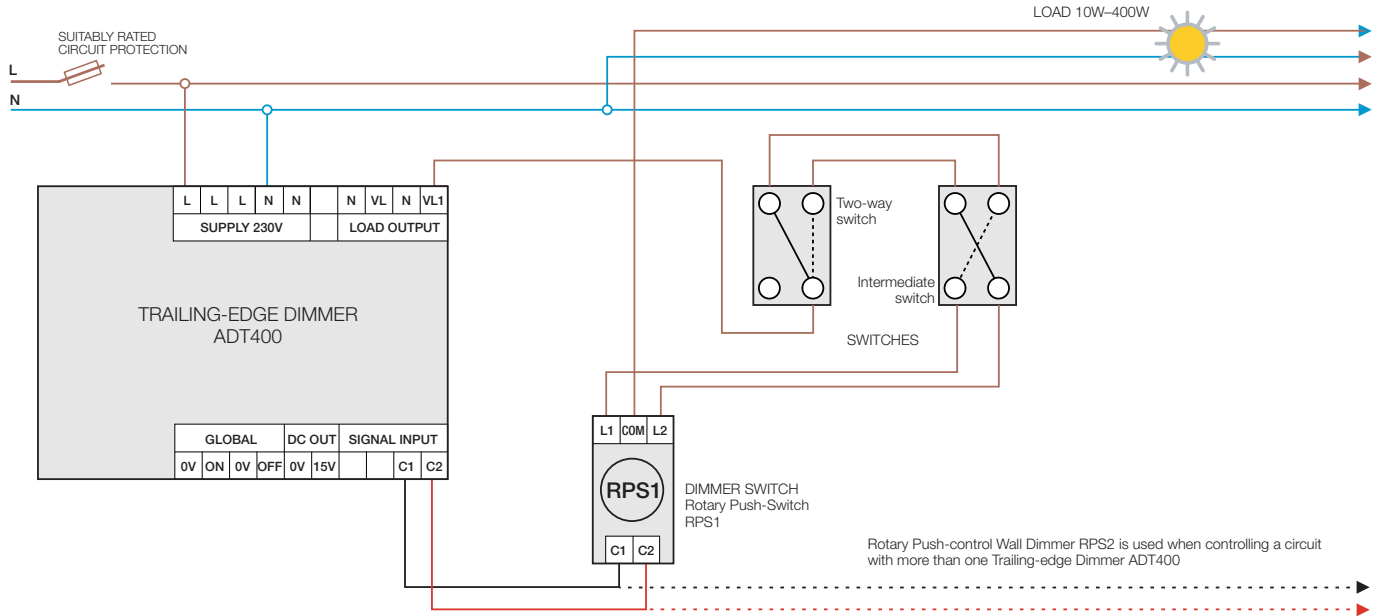

DRAWING NOT TO SCALE WD-ADT400-RPS. ISS-1-0116

# Trailing-edge Dimmer ADT400 wired to Rotary Push-control Wall dimmer RPC using global output

Trailing-edge Dimmer ADT400 cabled to Rotary Push-control Wall Dimmer RPC1 using global output

If using global output with more two or more Trailing-edge Dimmer ADT400 loop global signal between units

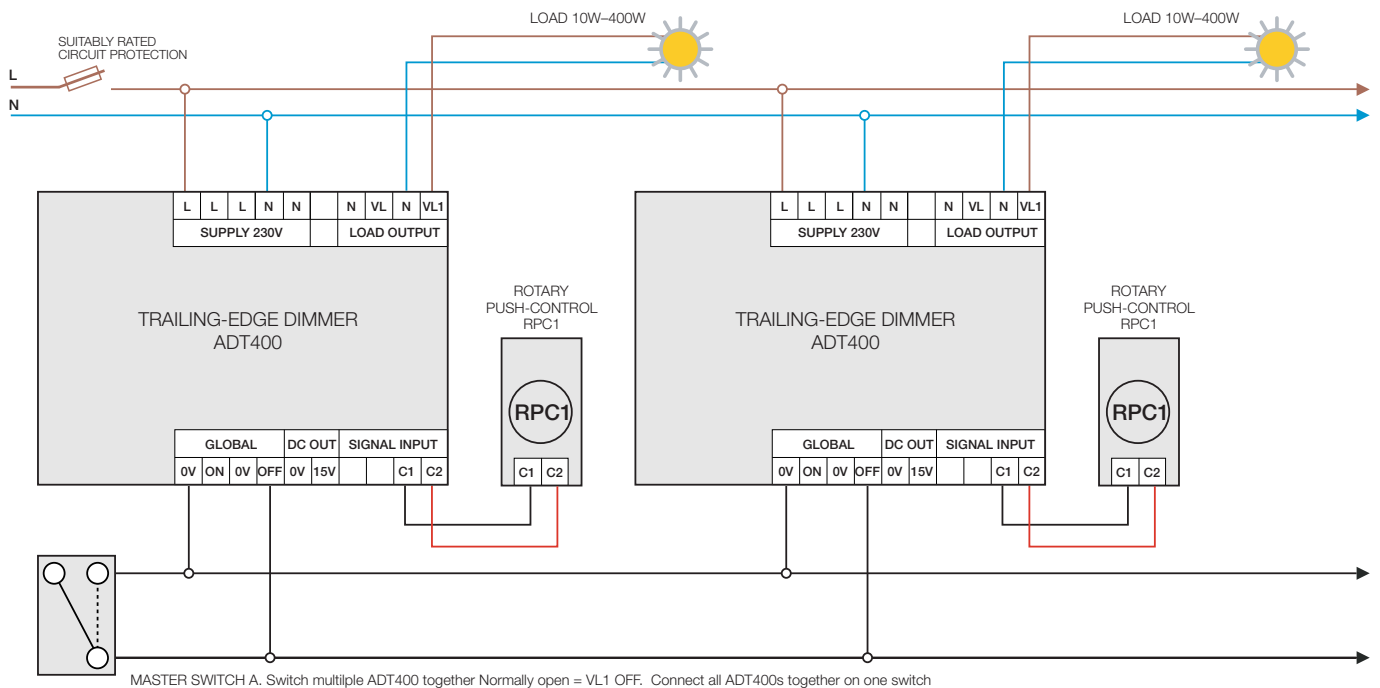

DRAWING NOT TO SCALE WD-ADT400-RPCG. ISS-1-0116



# Trailing-edge Dimmer ADT400 wired to a MoodMaker channel

Trailing-edge Dimmer ADT400 cabled to a channel of the MoodMaker Scene-setting system base board MMSU

Use channels C to F for cabling Trailing-edge Dimmer ADT400 to a channel of MoodMaker

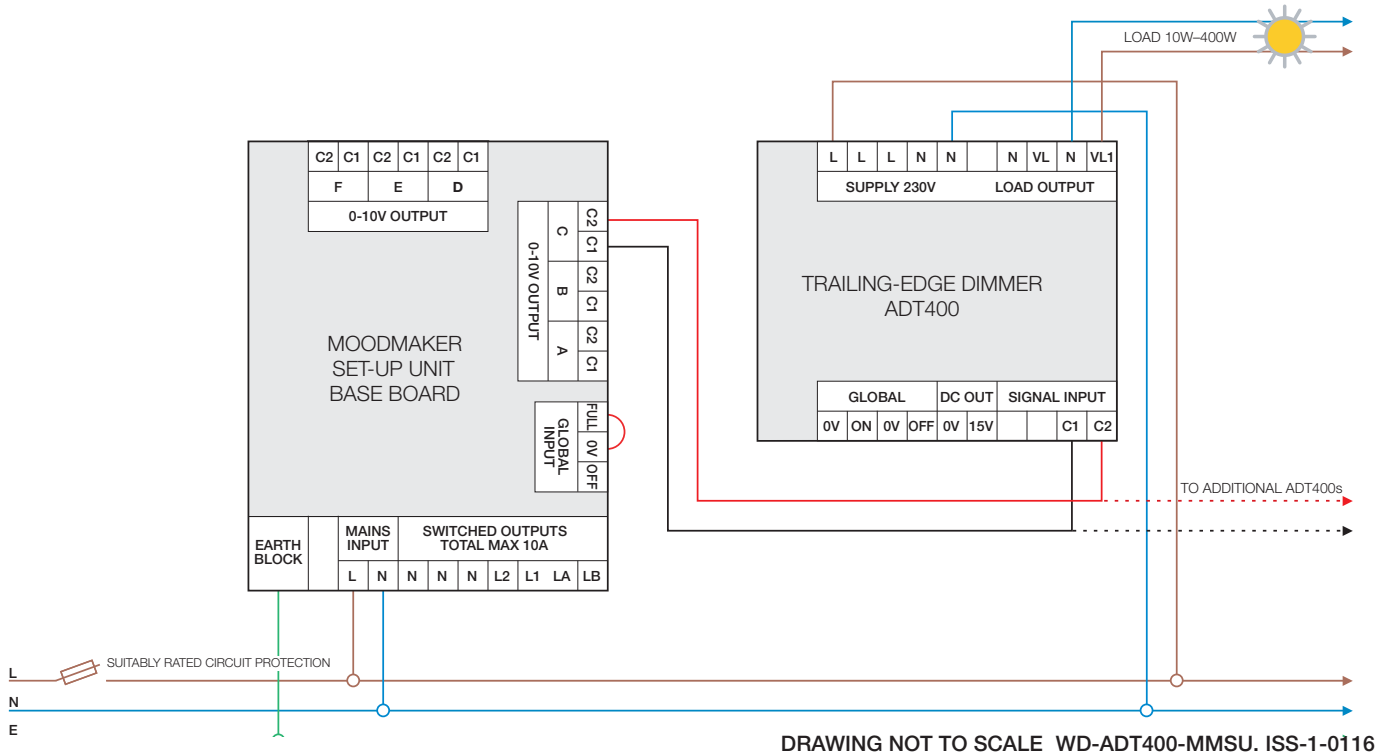

# Trailing-edge Dimmer ADT400 wired to Take Control Unit with multiple position rotary dimming

Take Control Unit TCU100 showing four push-switch rotary Wall Dimmers TCR connected

